

Parallel Programming Principle and Practice

Lecture 6 — Shared Memory Programming OpenMP

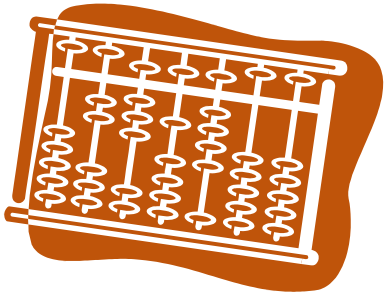

Jin, Hai

School of Computer Science and Technology
Huazhong University of Science and Technology

Outline



- OpenMP Overview
- Creating Threads
- Parallel Loops
- Synchronization
- Data Environment
- Tasks

Architecture for Shared Memory Model

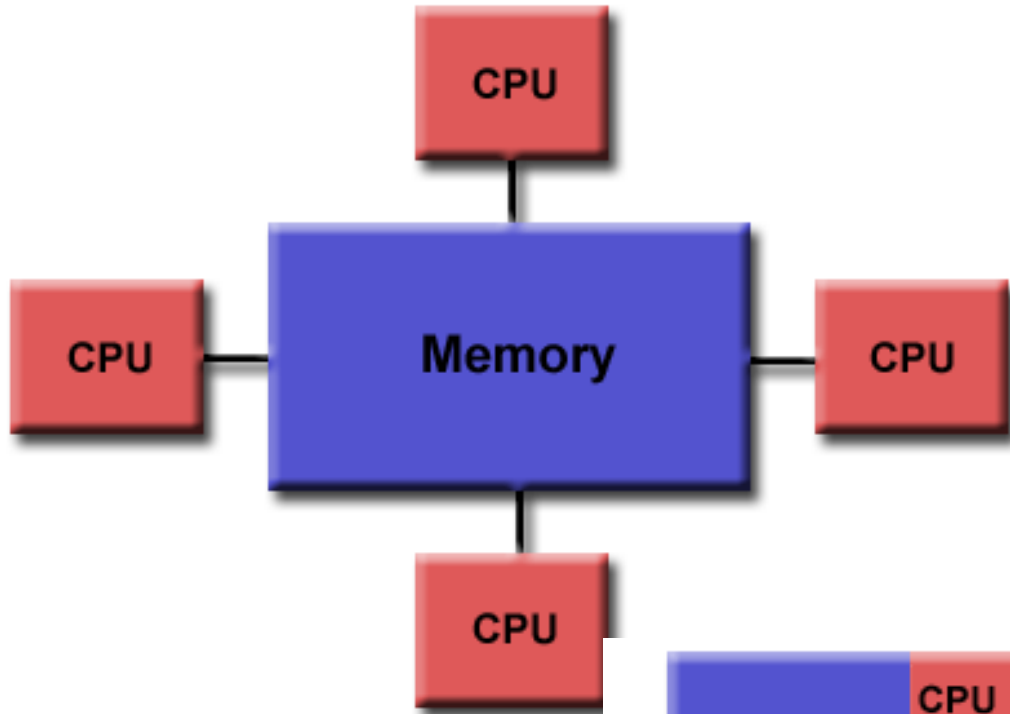

Uniform Memory Access

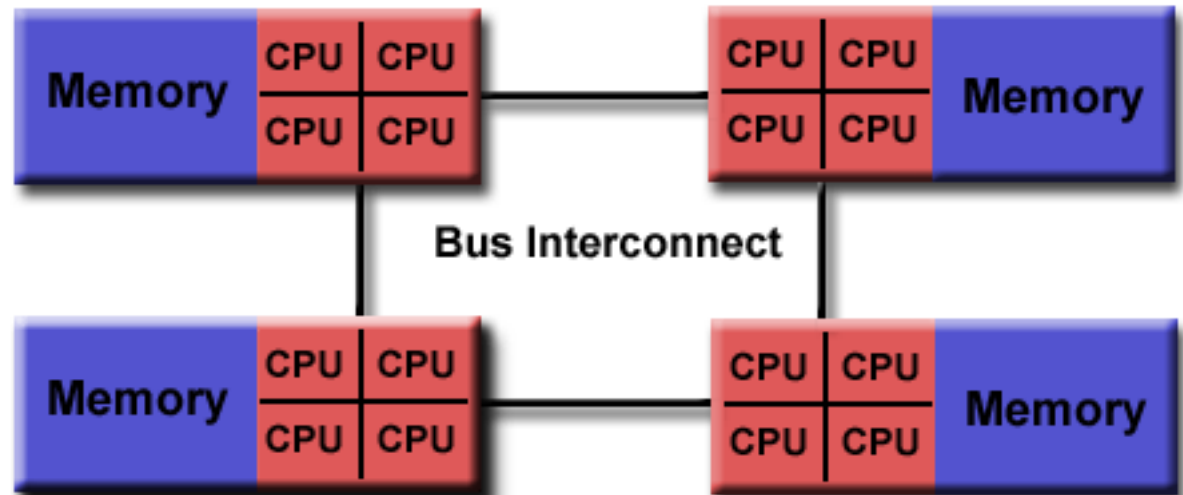

Non-Uniform Memory Access

Thread Based Parallelism

- ❑ OpenMP programs accomplish parallelism exclusively through the use of threads
- ❑ A thread of execution is the smallest unit of processing that can be scheduled by an operating system
 - The idea of a subroutine that can be scheduled to run autonomously might help explain what a thread is
- ❑ Threads exist within the resources of a single process
 - Without the process, they cease to exist
- ❑ Typically, the number of threads match the number of machine processors/cores
 - However, the actual use of threads is up to the application

Explicit Parallelism

- ❑ OpenMP is an explicit (not automatic) programming model, offering the programmer full control over parallelization
- ❑ Parallelization can be as simple as taking a serial program and inserting compiler directives....
- ❑ Or as complex as inserting subroutines to set multiple levels of parallelism, locks and even nested locks

OpenMP Overview

C\$OMP FLUSH

#pragma omp critical

C\$OMP THREADPRIVATE (/ABC/)

CALL OMP SET NUM THREADS(10)

OpenMP: An API for Writing Multithreaded Applications

- A set of compiler directives and library routines for parallel application programmers
- Greatly simplifies writing multi-threaded (MT) programs in Fortran, C and C++
- Standardizes last 20 years of SMP practice

C\$OMP PARALLEL COPYIN (/blk/)

C\$OMP DO lastprivate (XX)

Nthrds = OMP_GET_NUM_PROCS()

omp_set_lock(lck)

OpenMP Release History

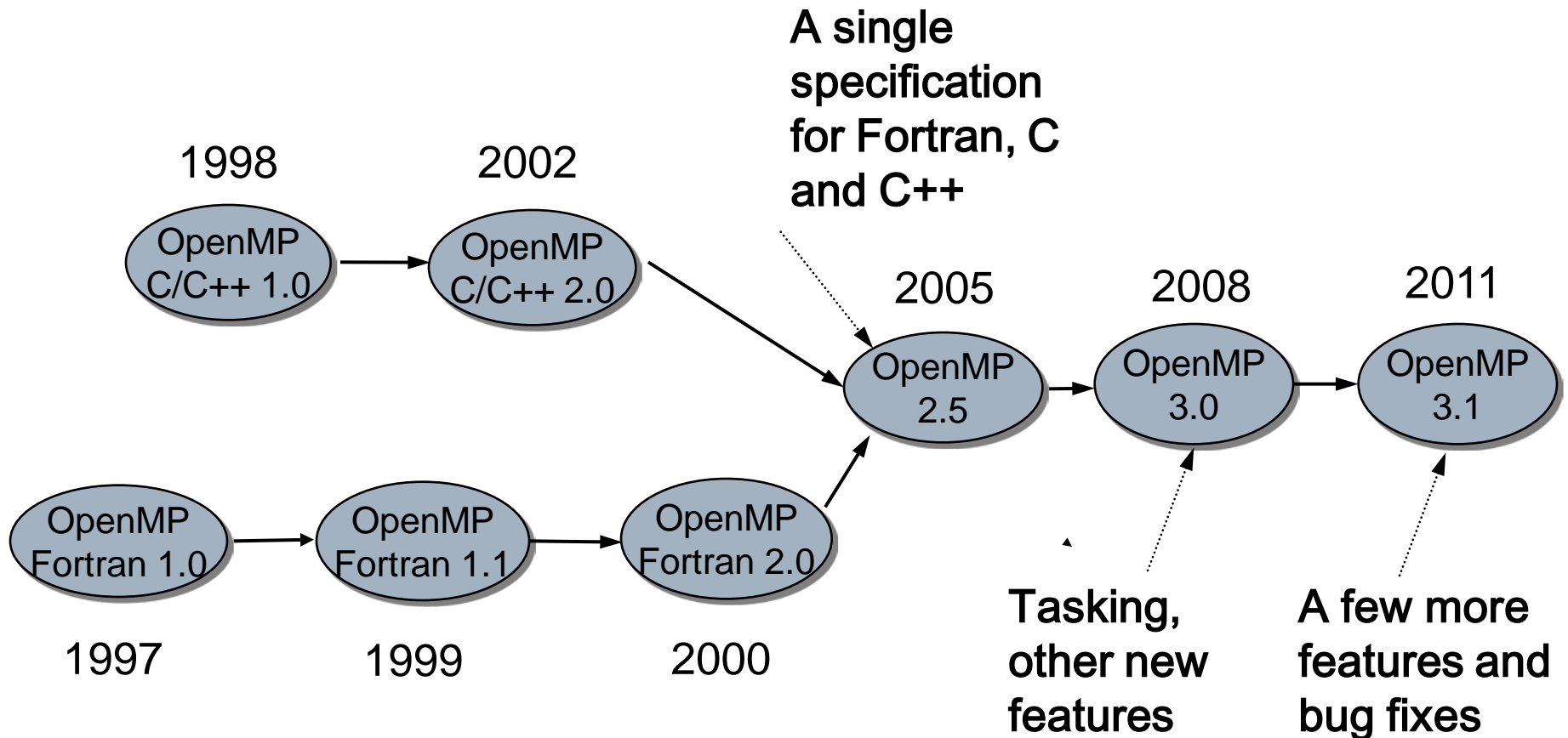

OpenMP Core Syntax

- Most of the constructs in OpenMP are compiler directives
 - `#pragma omp construct [clause [clause]...]`
 - Example
 - `#pragma omp parallel num_threads(4)`**
- Function prototypes and types in the file
 - `#include <omp.h>`
- Most OpenMP constructs apply to a **structured block**
 - Structured block: a block of one or more statements with one point of entry at the top and one point of exit at the bottom
 - It's OK to have an `exit()` within the structured block

OpenMP Overview: How do Threads Interact?

- ❑ OpenMP is a multi-threading, shared address model
 - Threads communicate by sharing variables
- ❑ Unintended sharing of data causes race conditions
 - Race condition: when the program's outcome changes as the threads are scheduled differently
- ❑ To control race conditions
 - Use synchronization to protect data conflicts
- ❑ Synchronization is expensive
 - Change how data is accessed to minimize the need for synchronization

Outline

- OpenMP Overview
- **Creating Threads**
- Parallel Loops
- Synchronization
- Data Environment
- Tasks



OpenMP Programming Model

Fork-Join Parallelism

- ◆ All OpenMP programs begin as a single process: the **master thread**. The master thread executes sequentially until the first **parallel region** construct is encountered
- ◆ **Master thread** spawns a **team of threads** as needed
- ◆ Parallelism added incrementally until performance goals are met: i.e. the sequential program evolves into a parallel program

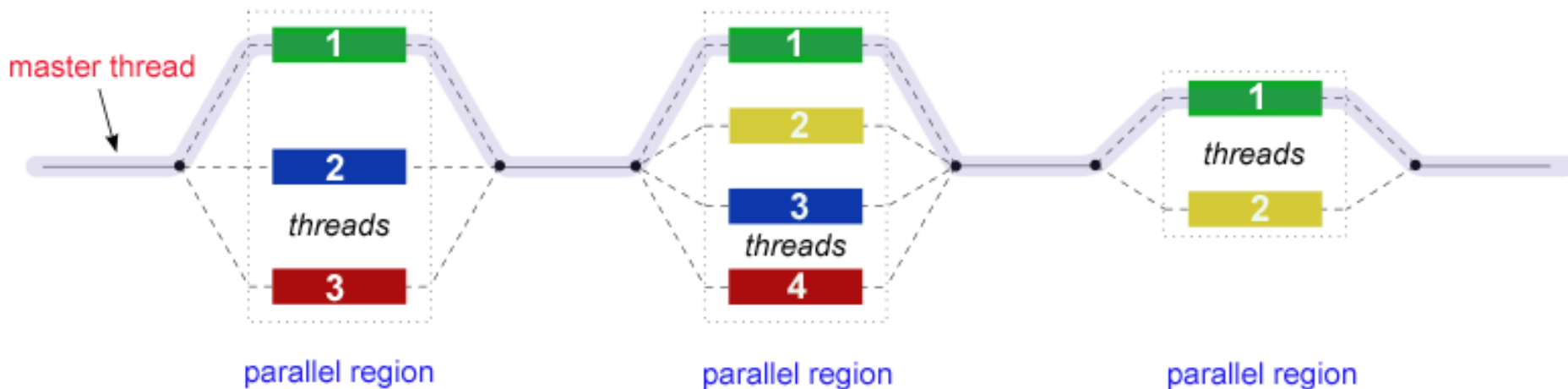

Thread Creation: Parallel Regions

- ❑ Create threads in OpenMP with the *parallel* construct
- ❑ For example, to create a 4 thread in parallel region

Each thread executes a copy of the code within the structured block

```
double A[1000];
```

```
#pragma omp parallel num_threads(4)
{
    int ID = omp_get_thread_num();
    pooh(ID,A);
}
```

clause to request a certain number of threads

Runtime function returning a thread ID

- **Each thread calls `pooh(ID,A)` for `ID = 0 to 3`**

Thread Creation: Parallel Regions

- Each thread executes the same code redundantly

```
double A[1000];
#pragma omp parallel num_threads(4)
{
    int ID = omp_get_thread_num();
    pooh(ID, A);
}
printf("all done\n");
```

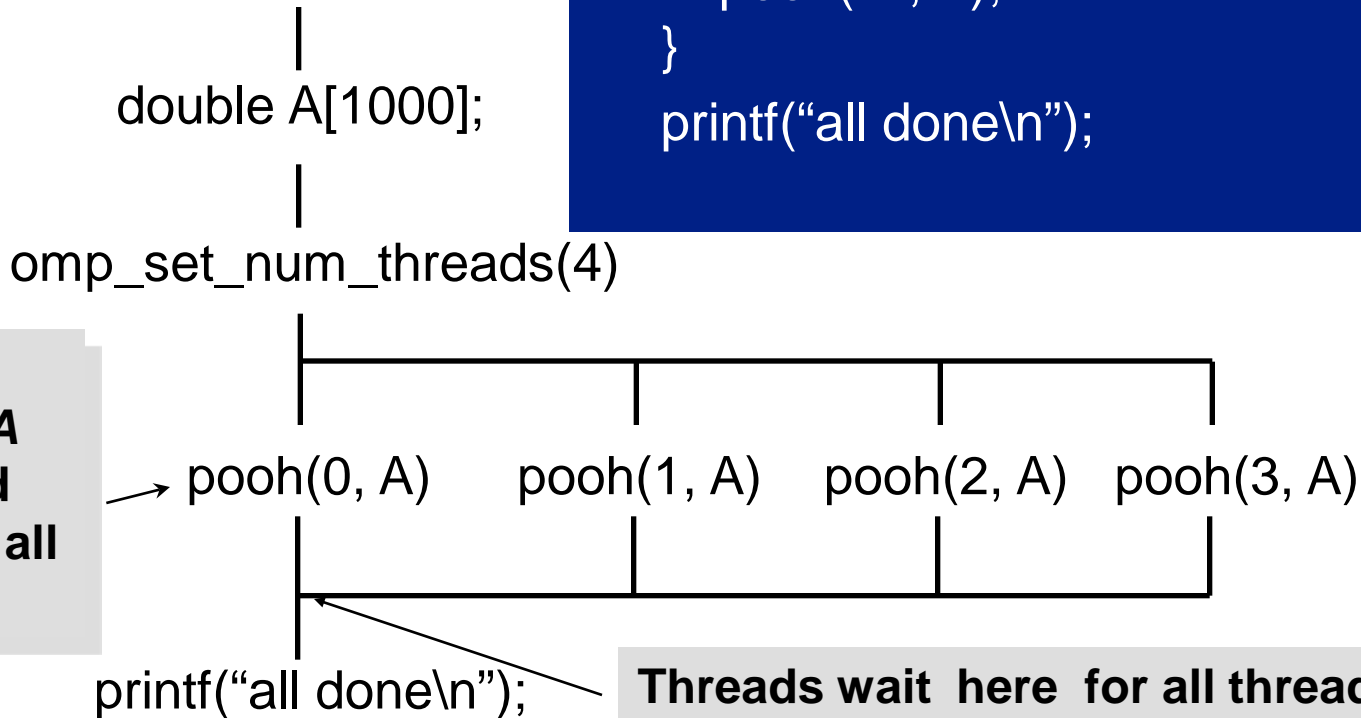

A single copy of A is shared between all threads

Threads wait here for all threads to finish before proceeding (i.e. a barrier)

Outline

- OpenMP Overview
- Creating Threads
- **Parallel Loops**
- Synchronization
- Data Environment
- Tasks



Loop Worksharing Constructs

- Loop worksharing construct splits up loop iterations among the threads in a team

```
#pragma omp parallel
{
#pragma omp for
    for (I=0;I<N;I++){
        NEAT_STUFF(I);
    }
}
```

Loop construct name

- C/C++: *for*
- Fortran: *do*

The variable *I* is made “private” to each thread by default. You could do this explicitly with a “private(I)” clause

Loop Worksharing Constructs

A Motivating Example

Sequential code

```
for(i=0;i<N;i++) { a[i] = a[i] + b[i];}
```

OpenMP parallel region

```
#pragma omp parallel
{
    int id, i, Nthrds, istart, iend;
    id = omp_get_thread_num();
    Nthrds = omp_get_num_threads();
    istart = id * N / Nthrds;
    iend = (id+1) * N / Nthrds;
    if (id == Nthrds-1) iend = N;
    for(i=istart;i<iend;i++) { a[i] = a[i] + b[i];}
}
```

OpenMP parallel region and a worksharing for construct

```
#pragma omp parallel
#pragma omp for
    for(i=0;i<N;i++) { a[i] = a[i] + b[i];}
```

Loop Worksharing Constructs: The *schedule* clause

- The *schedule* clause affects how loop iterations are mapped onto threads
 - *schedule*(static[,chunk])
 - ✓ Deal-out blocks of iterations of size “chunk” to each thread
 - *schedule*(dynamic[,chunk])
 - ✓ Each thread grabs “chunk” iterations off a queue until all iterations have been handled
 - *schedule*(guided[,chunk])
 - ✓ Threads dynamically grab blocks of iterations. The size of the block starts large and shrinks down to size “chunk” as the calculation proceeds
 - *schedule*(runtime)
 - ✓ Schedule and chunk size taken from the OMP_SCHEDULE environment variable (or the runtime library)
 - *schedule*(auto)
 - ✓ Schedule is left up to the runtime to choose (does not have to be any of the above)

Loop Worksharing Constructs: The *schedule* clause

Schedule Clause	When To Use
STATIC	Pre-determined and predictable by the programmer
DYNAMIC	Unpredictable, highly variable work per iteration
GUIDED	Special case of dynamic to reduce scheduling overhead
AUTO	When the runtime can “learn” from previous executions of the same loop

Least work at runtime :
scheduling done at compile-time

Most work at runtime :
complex scheduling logic used at run-time

Working with Loops

□ Basic approach

- Find compute intensive loops
- Make the loop iterations independent .. So they can safely execute in any order without loop-carried dependencies
- Place the appropriate OpenMP directive and test

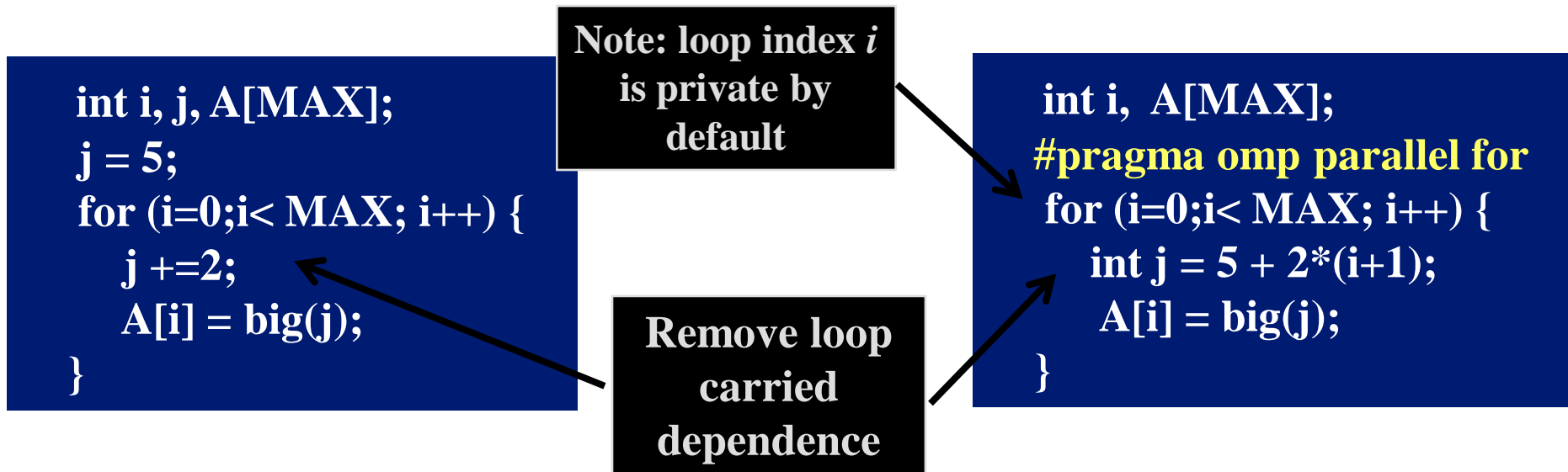

Nested Loops

- For perfectly nested rectangular loops we can parallelize multiple loops in the nest with the *collapse* clause

```
#pragma omp parallel for collapse(2)
for (int i=0; i<N; i++) {
    for (int j=0; j<M; j++) {
        . . . . .
    }
}
```

Number of loops to be parallelized, counting from the outside

- Will form a single loop of length $N \times M$ and then parallelize that
- Useful if N is $O(\text{no. of threads})$ so parallelizing the outer loop may not have good load balance

Rules for Collapse Clause

- ❑ Only one collapse clause is allowed on a worksharing **DO** or **PARALLEL DO** directive
- ❑ The specified number of loops must be present lexically. None of the loops can be in a called subroutine
- ❑ The loops must form a rectangular iteration space and the bounds and stride of each loop must be invariant over all the loops
- ❑ If the loop indices are of different size, the index with the largest size will be used for the collapsed loop
- ❑ The loops must be perfectly nested. There is no intervening code nor any OpenMP directive between the loops which are collapsed
- ❑ The associated do-loops must be structured blocks. Their execution must not be terminated by an **EXIT** statement
- ❑ If multiple loops are associated to the loop construct, only an iteration of the innermost associated loop may be curtailed by a **CYCLE** statement, and there must be no branches to any of the loop termination statements except for the innermost associated loop

Reduction

- How do we handle this case?

```
double ave=0.0,A[MAX]; int i;
for (i=0;i< MAX; i++) {
    ave += A[i];
}
ave = ave/MAX;
```

- We are combining values into a single accumulation variable (ave) ... there is a true dependence between loop iterations that can't be trivially removed
- This is a very common situation ... it is called a **reduction**
- Support for reduction operations is included in most parallel programming environments

Reduction

- OpenMP *reduction* clause
reduction (op : list)
- Inside a parallel or a worksharing construct
 - A local copy of each list variable is made and initialized depending on the *op* (e.g. 0 for “+”)
 - Updates occur on the local copy
 - Local copies are reduced into a single value and combined with the original global value
- The variables in *list* must be shared in the enclosing parallel region

```
double ave=0.0, A[MAX]; int i;
#pragma omp parallel for reduction (+:ave)
for (i=0;i< MAX; i++) {
    ave += A[i];
}
ave = ave/MAX;
```

OpenMP: Reduction Operands/Initial Values

- Many different associative operands can be used with reduction
- Initial values are the ones that make sense mathematically

Operator	Initial value
+	0
*	1
-	0

C/C++ only	
Operator	Initial value
&	~0
	0
^	0
&&	1
	0

Fortran Only	
Operator	Initial value
.AND.	.true.
.OR.	.false.
.NEQV.	.false.
.IEOR.	0
.IOR.	0
.IAND.	All bits on
.EQV.	.true.
MIN	Largest pos. number
MAX	Most neg. number

Example: Numerical Integration

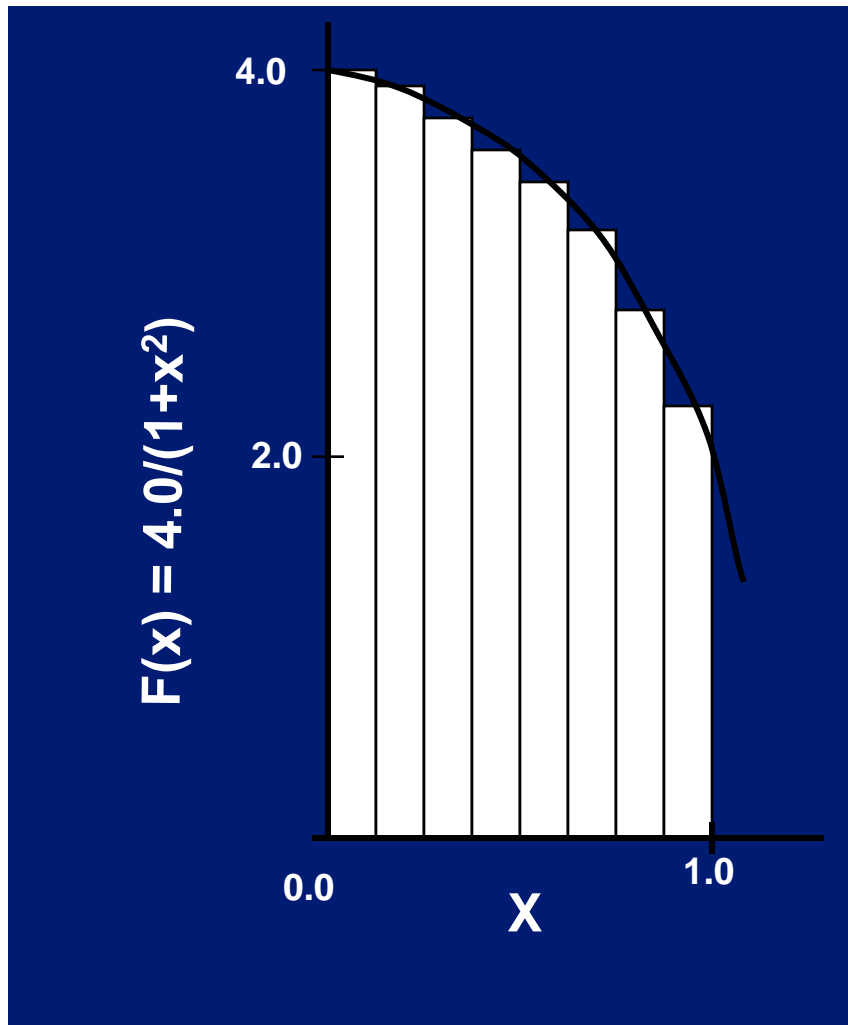

Mathematically, we know that:

$$\int_0^1 \frac{4.0}{(1+x^2)} dx = \pi$$

We can approximate the integral as a sum of rectangles:

$$\sum_{i=0}^N F(x_i) \Delta x \approx \pi$$

where each rectangle has width Δx and height $F(x_i)$ at the middle of interval i

Numerical Integration: Serial PI Program

```
static long num_steps = 100000;
double step;
void main ()
{
    int i;  double x, pi, sum = 0.0;

    step = 1.0/(double) num_steps;

    for (i=0;i< num_steps; i++){
        x = (i+0.5)*step;
        sum = sum + 4.0/(1.0+x*x);
    }
    pi = step * sum;
}
```

Numerical Integration: Solution

```

#include <omp.h>
static long num_steps = 100000;      double step;
void main ()
{   int i;  double x, pi, sum = 0.0;
    step = 1.0/(double) num_steps;
    #pragma omp parallel
    {
        double x;
        #pragma omp for reduction(+:sum)
        for (i=0;i< num_steps; i++){
            x = (i+0.5)*step;
            sum = sum + 4.0/(1.0+x*x);
        }
    }
    pi = step * sum;
}

```

Single Worksharing Construct

- The *single* construct denotes a block of code that is executed by only one thread (not necessarily the master thread)
- A barrier is implied at the end of the single block (can remove the barrier with a *nowait* clause)

```
#pragma omp parallel
{
    do_many_things();
#pragma omp single
    {   exchange_boundaries();   }
    do_many_other_things();
}
```

Outline

- OpenMP Overview
- Creating Threads
- Parallel Loops
- Synchronization
- Data Environment
- Tasks

The logo for OpenMP, featuring the text "OpenMP" in a teal, sans-serif font. The "O" and "P" are larger and more prominent. The text is set against a background of two horizontal teal bars, one above and one below the text.

Synchronization

- High level synchronization
 - critical
 - atomic
 - barrier
 - ordered
- Low level synchronization
 - flush

Synchronization is used to impose order constraints and to protect access to shared data

Synchronization: Critical

- Mutual exclusion: Only one thread at a time can enter a *critical* region

```
float res;  
  
#pragma omp parallel  
{ float B; int i, id, nthrds;  
  id = omp_get_thread_num();  
  nthrds = omp_get_num_threads();  
  for(i=id;i<niters;i+=nthrds){  
    B = big_job(i);  
    #pragma omp critical  
    res += consume (B);  
  }  
}
```

Threads wait
their turn –
only one at a
time calls
consume()

Synchronization: Atomic

- *atomic* provides mutual exclusion but only applies to the update of a memory location (the update of X in the following example)

```
#pragma omp parallel  
{  
    double tmp, B;  
    B = DOIT();  
    tmp = big_ugly(B);  
#pragma omp atomic  
    X += tmp;  
}
```

Atomic only protects the read/update of X

Synchronization: Barrier

- *barrier*: Each thread waits until all threads arrive

```

#pragma omp parallel shared (A, B, C) private(id)
{
    id=omp_get_thread_num();
    A[id] = big_calc1(id);
    #pragma omp barrier
    #pragma omp for
    for(i=0;i<N;i++){
        C[i]=big_calc3(i,A);
    }
    #pragma omp for nowait
    for(i=0;i<N;i++){
        B[i]=big_calc2(C, i);
    }
    A[id] = big_calc4(id);
}
    
```

implicit *barrier* at the end of a for worksharing construct

no implicit *barrier* due to *nowait*

implicit *barrier* at the end of a parallel region

Master Construct

- ❑ The **master** construct denotes a structured block that is only executed by the master thread
- ❑ The other threads just skip it (no synchronization is implied)

```
#pragma omp parallel
{
    do_many_things();
    #pragma omp master
        { exchange_boundaries(); }
    #pragma omp barrier
        do_many_other_things();
}
```

Outline

- OpenMP Overview
- Creating Threads
- Parallel Loops
- Synchronization
- Data Environment
- Tasks

The logo for OpenMP, featuring the text "OpenMP" in a teal, sans-serif font. The "O" and "P" are larger and more prominent. A horizontal teal bar is positioned above the text, and another horizontal teal bar is positioned below the text, framing the logo.

Data Environment: Default Storage Attributes

- ❑ Shared memory programming model
 - ✓ Most variables are shared by default
- ❑ Global variables are SHARED among threads
 - ✓ Fortran: COMMON blocks, SAVE variables, MODULE variables
 - ✓ C: File scope variables, static
 - ✓ Both: dynamically allocated memory (ALLOCATE, malloc, new)
- ❑ But not everything is shared...
 - ✓ Stack variables in subprograms (Fortran) or functions (C) called from parallel regions are PRIVATE
 - ✓ Automatic variables within a statement block are PRIVATE

Data Sharing: Examples

```
double A[10];
int main() {
    int index[10];
    #pragma omp parallel
        work(index);
    printf(“%d\n”, index[0]);
}
```

```
extern double A[10];
void work(int *index) {
    double temp[10];
    static int count;
    ...
}
```

***A*, *index* and *count* are shared by all threads**

***temp* is local to each thread**

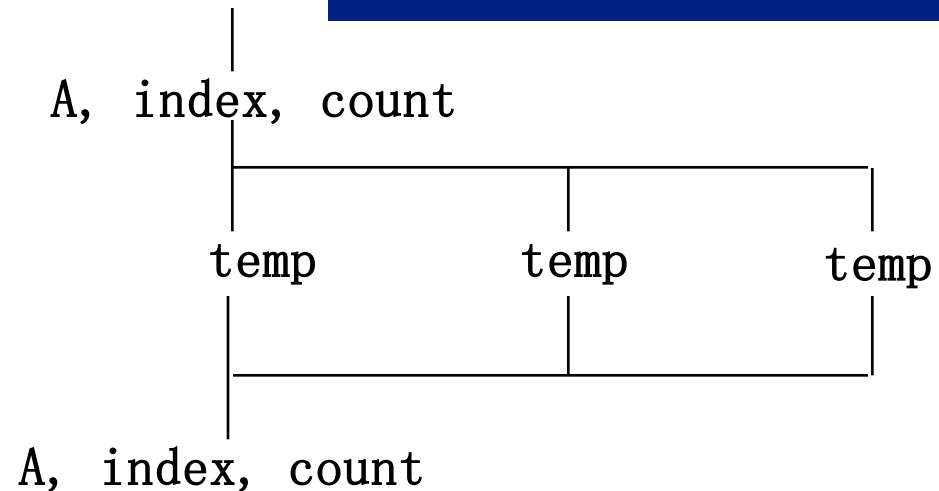

Data Sharing: Changing Storage Attributes

- ❑ One can selectively change storage attributes for constructs using the following clauses*

- ✓ SHARED
- ✓ PRIVATE
- ✓ FIRSTPRIVATE

All the clauses on this page apply to the OpenMP construct NOT to the entire region

- ❑ The final value of a private inside a parallel loop can be transmitted to the shared variable outside the loop with

- ✓ LASTPRIVATE

- ❑ The default attributes can be overridden with

- ✓ DEFAULT (PRIVATE | SHARED | NONE)

DEFAULT(PRIVATE) *is Fortran only*

All data clauses apply to parallel constructs and worksharing constructs except “shared” which only applies to parallel constructs.

Data Sharing: Private Clause

- `private(var)` creates a new local copy of `var` for each thread
 - ✓ The value of the private copies is uninitialized
 - ✓ The value of the original variable is unchanged after the region

```
void wrong() {  
    int tmp = 0;  
    #pragma omp parallel for private(tmp)  
    for (int j = 0; j < 1000; ++j)  
        tmp += j;  
    printf("%d\n", tmp);  
}
```

tmp was not
initialized

tmp is 0 here

Data Sharing: Private Clause

When is Original Variable Valid?

- The original variable's value is unspecified if it is referenced outside of the construct
 - ✓ Implementations may reference the original variable or a copy a dangerous programming practice!

```
int tmp;  
void danger() {  
    tmp = 0;  
#pragma omp parallel private(tmp)  
    work();  
    printf("%d\n", tmp);  
}
```

tmp has unspecified value

```
extern int tmp;  
void work() {  
    tmp = 5;  
}
```

unspecified which copy of tmp

Firstprivate Clause

- ❑ Variables initialized from shared variable
- ❑ C++ objects are copy-constructed

```
incr = 0;
#pragma omp parallel for firstprivate(incr)
for (i = 0; i <= MAX; i++) {
    if ((i%2)==0) incr++;
    A[i] = incr;
}
```

Each thread gets its own copy of *incr* with an initial value of 0

Lastprivate Clause

- Variables update shared variable using value from last iteration
- C++ objects are updated as if by assignment

```
void sq2(int n, double *lastterm)
{
    double x; int i;
    #pragma omp parallel for lastprivate(x)
    for (i = 0; i < n; i++) {
        x = a[i]*a[i] + b[i]*b[i];
        b[i] = sqrt(x);
    }
    *lastterm = x;
}
```

x has the value it held for the last sequential iteration (i.e., for $i=(n-1)$)

Data Sharing: Default Clause

- Note that the default storage attribute is **DEFAULT(SHARED)** (so no need to use it)
 - Exception: **#pragma omp task**
- To change default: **DEFAULT(PRIVATE)**
 - *each* variable in the construct is made private as if specified in a private clause
 - mostly saves typing
- **DEFAULT(NONE)**: *no* default for variables in static extent. Must list storage attribute for each variable in static extent. Good programming practice!

Only the Fortran API supports default(private).

C/C++ only has default(shared) or default(none).

Outline

- OpenMP Overview
- Creating Threads
- Parallel Loops
- Synchronization
- Data Environment
- **Tasks**

The logo for OpenMP, featuring the text "OpenMP" in a teal, sans-serif font. The "O" and "P" are underlined with a thick teal bar. A small "TM" trademark symbol is located at the bottom right of the "P".

What are Tasks?

- Tasks are independent units of work
- Threads are assigned to perform the work of each task
 - Tasks may be deferred
- Tasks may be executed immediately
- The runtime system decides which of the above
- Tasks are composed of
 - code to execute
 - data environment
 - internal control variables (ICV)

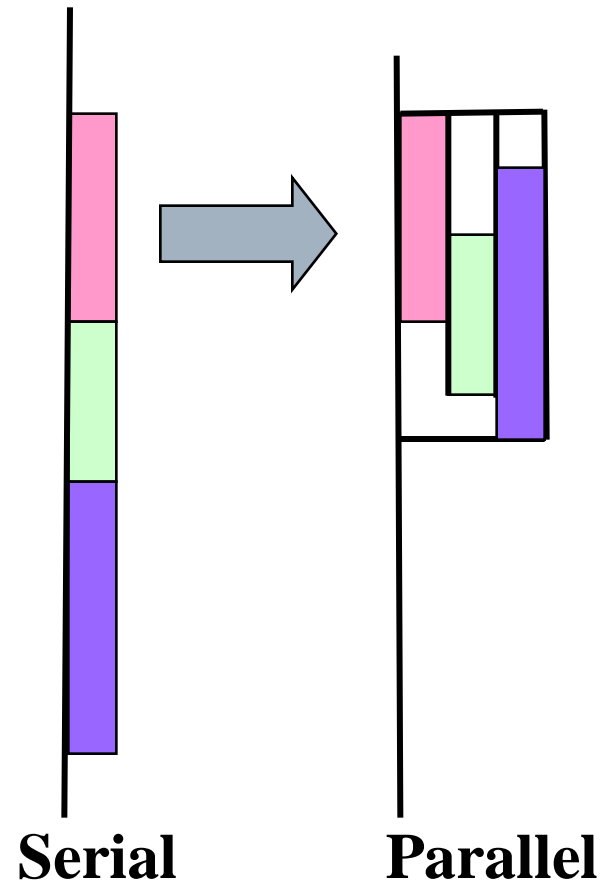

Task Construct – Explicit Task View

- A team of threads is created at the `omp parallel` construct
- A single thread is chosen to execute the while loop – lets call this thread “L”
- Thread L operates the while loop, creates tasks, and fetches next pointers
- Each time L crosses the `omp task` construct it generates a new task and has a thread assigned to it
- Each task runs in its own thread
- All tasks complete at the barrier at the end of the parallel region’s `single` construct

```
#pragma omp parallel
{
  #pragma omp single
  { // block 1
    node * p = head;
    while (p) { //block 2
      #pragma omp task private(p)
        process(p);
      p = p->next; //block 3
    }
  }
}
```

Simple Task Example

```
#pragma omp parallel num_threads(8)
// assume 8 threads
{
  #pragma omp single private(p)
  {
    ...
    while (p) {
      #pragma omp task
      {
        processwork(p);
      }
      p = p->next;
    }
  }
}
```

A pool of 8 threads is created here

One thread gets to execute the while loop

The single “while loop” thread creates a task for each instance of processwork()

Why are Tasks Useful?

Have potential to parallelize irregular patterns and recursive function calls

```

#pragma omp parallel
{
  #pragma omp single
  { // block 1
    node * p = head;
    while (p) { //block 2
      #pragma omp task
      process(p);
      p = p->next; //block 3
    }
  }
}

```

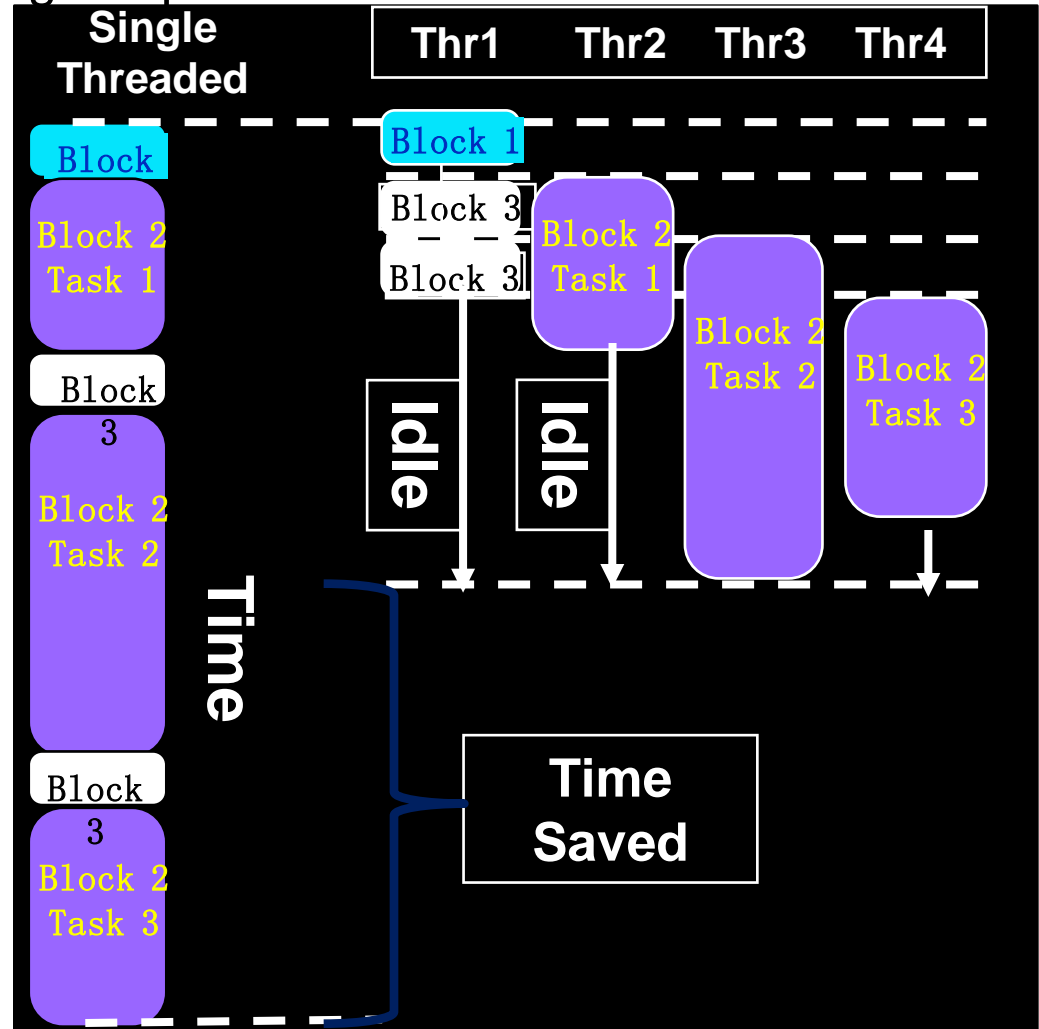

When are Tasks Guaranteed to Complete

- Tasks are guaranteed to be complete at thread barriers

`#pragma omp barrier`

- ... or task barriers

`#pragma omp taskwait`

Task Completion Example

```
#pragma omp parallel
{
  #pragma omp task
  foo();
  #pragma omp barrier
  #pragma omp single
  {
    #pragma omp task
    bar();
  }
}
```

Multiple foo tasks created here – one for each thread

All foo tasks guaranteed to be completed here

One bar task created here

bar task guaranteed to be completed here

Recursive Matrix Multiplication

- Consider recursive matrix multiplication, described in next 3 slides
 - How would you parallelize this program using OpenMP tasks?
 - What data considerations need to be addressed?

Recursive Matrix Multiplication

- Quarter each input matrix and output matrix
- Treat each submatrix as a single element and multiply
- 8 submatrix multiplications, 4 additions

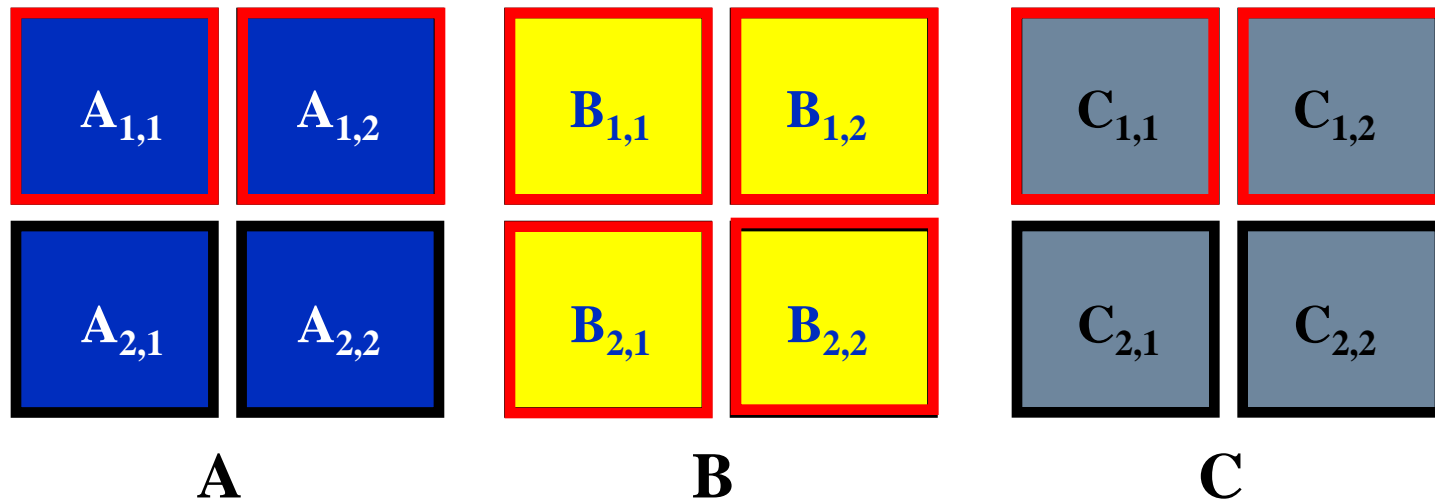

$$C_{1,1} = A_{1,1} \cdot B_{1,1} + A_{1,2} \cdot B_{2,1}$$

$$C_{2,1} = A_{2,1} \cdot B_{1,1} + A_{2,2} \cdot B_{2,1}$$

$$C_{1,2} = A_{1,1} \cdot B_{1,2} + A_{1,2} \cdot B_{2,2}$$

$$C_{2,2} = A_{2,1} \cdot B_{1,2} + A_{2,2} \cdot B_{2,2}$$

How to Multiply Submatrices?

- Use the same routine that is computing the full matrix multiplication
 - Quarter each input submatrix and output submatrix
 - Treat each sub-submatrix as a single element and multiply

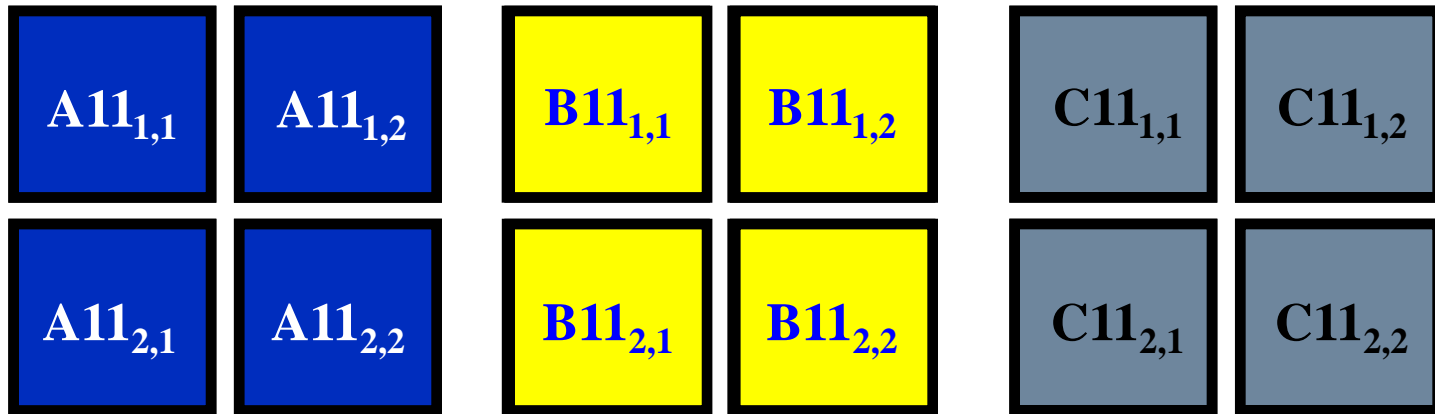

$\mathbf{A}_{1,1}$

$\mathbf{B}_{1,1}$

$\mathbf{C}_{1,1}$

$$\mathbf{C}_{1,1} = \mathbf{A}_{1,1} \cdot \mathbf{B}_{1,1} + \mathbf{A}_{1,2} \cdot \mathbf{B}_{2,1}$$



$$\mathbf{C11}_{1,1} = \mathbf{A11}_{1,1} \cdot \mathbf{B11}_{1,1} + \mathbf{A11}_{1,2} \cdot \mathbf{B11}_{2,1}$$

Recursively Multiply Submatrices

$$C_{1,1} = A_{1,1} \cdot B_{1,1} + A_{1,2} \cdot B_{2,1}$$

$$C_{1,2} = A_{1,1} \cdot B_{1,2} + A_{1,2} \cdot B_{2,2}$$

$$C_{2,1} = A_{2,1} \cdot B_{1,1} + A_{2,2} \cdot B_{2,1}$$

$$C_{2,2} = A_{2,1} \cdot B_{1,2} + A_{2,2} \cdot B_{2,2}$$

- Need range of indices to define each submatrix to be used

```
void matmultrec(int mf, int ml, int nf, int nl, int pf, int pl,
               double **A, double **B, double **C)
{ // Dimensions: A[mf..ml][pf..pl]    B[pf..pl][nf..nl]    C[mf..ml][nf..nl]

  // C11 += A11*B11
    matmultrec(mf, mf+(ml - mf) / 2, nf, nf+(nl - nf) / 2, pf, pf+(pl - pf) / 2, A, B, C);
  // C11 += A12*B21
    matmultrec(mf, mf+(ml - mf) / 2, nf, nf+(nl - nf) / 2, pf+(pl - pf) / 2, pl, A, B, C);
  . . .
}
```

- Also need stopping criteria for recursion

Recursive Solution

```

#define THRESHOLD 32768 // product size below which simple matmult code is called

void matmultrec(int mf, int ml, int nf, int nl, int pf, int pl,
                double **A, double **B, double **C)

// Dimensions: A[mf..ml][pf..pl]   B[pf..pl][nf..nl]   C[mf..ml][nf..nl]

{
    if ((ml - mf) * (nl - nf) * (pl - pf) < THRESHOLD)
        matmult (mf, ml, nf, nl, pf, pl, A, B, C);
    else
    {
        #pragma omp task
        {
            matmultrec(mf, mf+(ml - mf)/2, nf, nf+(nl - nf)/2, pf, pf+(pl - pf)/2, A, B, C); // C11 += A11*B11
            matmultrec(mf, mf+(ml - mf)/2, nf, nf+(nl - nf)/2, pf+(pl - pf)/2, pl, A, B, C); // C11 += A12*B21
        }
        #pragma omp task
        {
            matmultrec(mf, mf+(ml - mf)/2, nf+(nl - nf)/2, nl, pf, pf+(pl - pf)/2, A, B, C); // C12 += A11*B12
            matmultrec(mf, mf+(ml - mf)/2, nf+(nl - nf)/2, nl, pf+(pl - pf)/2, pl, A, B, C); // C12 += A12*B22
        }
        #pragma omp task
        {
            matmultrec(mf+(ml - mf)/2, ml, nf, nf+(nl - nf)/2, pf, pf+(pl - pf)/2, A, B, C); // C21 += A21*B11
            matmultrec(mf+(ml - mf)/2, ml, nf, nf+(nl - nf)/2, pf+(pl - pf)/2, pl, A, B, C); // C21 += A22*B21
        }
        #pragma omp task
        {
            matmultrec(mf+(ml - mf)/2, ml, nf+(nl - nf)/2, nl, pf, pf+(pl - pf)/2, A, B, C); // C22 += A21*B12
            matmultrec(mf+(ml - mf)/2, ml, nf+(nl - nf)/2, nl, pf+(pl - pf)/2, pl, A, B, C); // C22 += A22*B22
        }
        #pragma omp taskwait
    }
}

```

- Could be executed in parallel as 4 tasks
 - Each task executes the two calls for the same output submatrix of C

International Workshop on OpenMP (IWOMP)



10th International Workshop on OpenMP

September 28 to 30, 2014

SENAI CIMATEC - SALVADOR | BAHIA | BRAZIL

The International Workshop on OpenMP (IWOMP) is an annual workshop dedicated to the promotion and advancement of all aspects of parallel programming with OpenMP. It is the premier forum to present and discuss

References

- The content expressed in this chapter comes from
 - Clay Breshears, Intel Corp. clay.breshears@intel.com
 - J. Mark Bull, EPCC, The University of Edinburgh, markb@epcc.ed.ac.uk
 - Tim Mattson, Intel Corp. timothy.g.mattson@intel.com
 - Lawrence Livermore National Laboratory, OpenMP Tutorial, <https://computing.llnl.gov/tutorials/openMP/>